

LUBRICATION ORDER**LO 5-3820-205-12-2****30 September 1991**(Supersedes LO 5-3820-205-12-2,
dated 19 July 1984)

**CRUSHER, JAW: DIESEL AND ELECTRIC DRIVEN,
WHEEL MOUNTED, PNEUMATIC TIRES, 75 TON PER HOUR
EAGLE CRUSHER MODEL 5157 AND 5157A
(NSN 3820-00-783-7311)
EAGLE CRUSHER MODEL 5157B
(NSN 3820-00-880-0540)
COMPONENT OF
CRUSHING AND SCREENING PLANT: DIESEL AND
ELECTRIC DRIVEN, WHEEL MOUNTED, 75 TON PER HOUR**

Reference: TM 5-3820-205-10-2 and TM 5-3820-205-20-2

Intervals (on-condition or hard time) and the related man-hour times are based on normal operation. The man-hour time specified is the time you need to do all the services prescribed for a particular interval. On-condition (OC) oil sample intervals shall be applied unless changed by the Army Oil Analysis Program (AOAP) laboratory. Change the hard time interval if your lubricants are contaminated or if you are operating the equipment under adverse operating conditions, including longer-than-usual operating hours. The hard time interval may be extended during periods of low activity. If extended, adequate preservation precautions must be taken. Hard time intervals will be applied in the event AOAP laboratory support is not available.

WARNING

Dry cleaning solvent, P-D-680, is toxic and flammable. Always wear protective goggles and gloves, and use only in a well-ventilated area. Avoid contact with skin, eyes, and clothes, and DO NOT breathe vapors. DO NOT use near open flame or excessive heat. The solvent's flash point is 100° F-138°F (38°C-59 C). If you become dizzy while using cleaning solvent, immediately get fresh air and medical help. If solvent contacts eyes, immediately wash your eyes and get medical aid.

Clean fittings before lubricating. Clean parts with dry cleaning solvent P-D-680, Type II or equivalent. Dry before lubricating.

Broken arrow shafts (- - -) indicate lubrication points on both sides of the equipment.

The lowest level of maintenance authorized to lubricate a point is indicated by one of the following: (C) for Crew/Operator, or (0) for Organizational Maintenance.

REPORTING ERRORS AND RECOMMENDING IMPROVEMENTS

You can help improve this manual. If you find any mistakes or if you know of a way to improve the procedures, please let us know. Mail your letter or DA Form 2028 (*Recommended Changes to Publications and Blank Forms*) direct to: Commander, U.S. Army Tank-Automotive Command, ATTN: AMSTA-MB, Warren, MI 48397-5000. A reply will be furnished to you.

Approved for public release; distribution is unlimited.

TA507858

LUBRICANT · INTERVAL

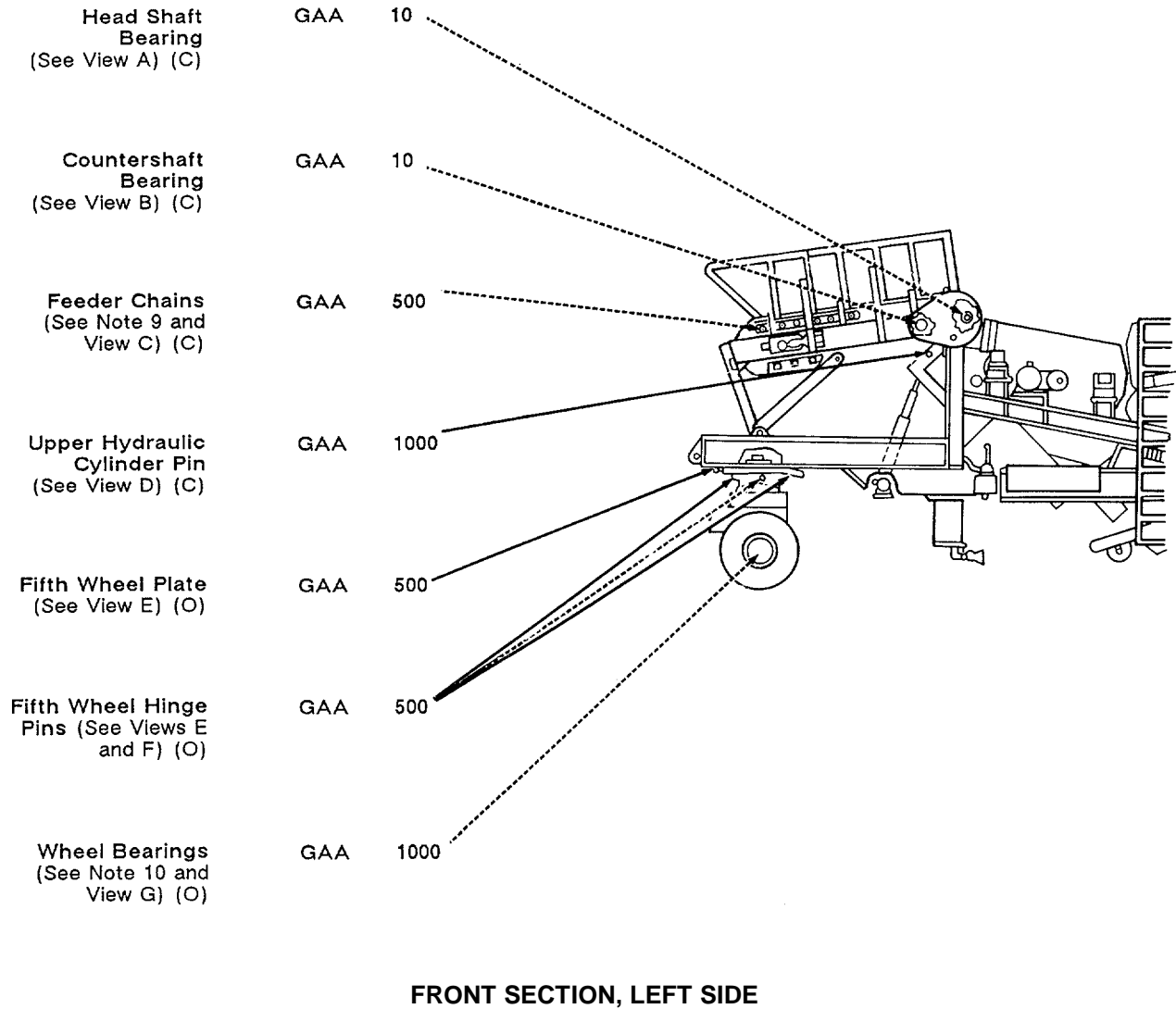

TOTAL MAN-HOURS*		TOTAL MAN-HOURS*	
INTERVAL	MAN-HOUR	INTERVAL	MAN-HOUR
10	1.0	1000	3.5
500	1.5		

The time specified is the time required to perform all services at the particular interval (on-condition or hard time).

TA507169

INTERVAL • LUBRICANT

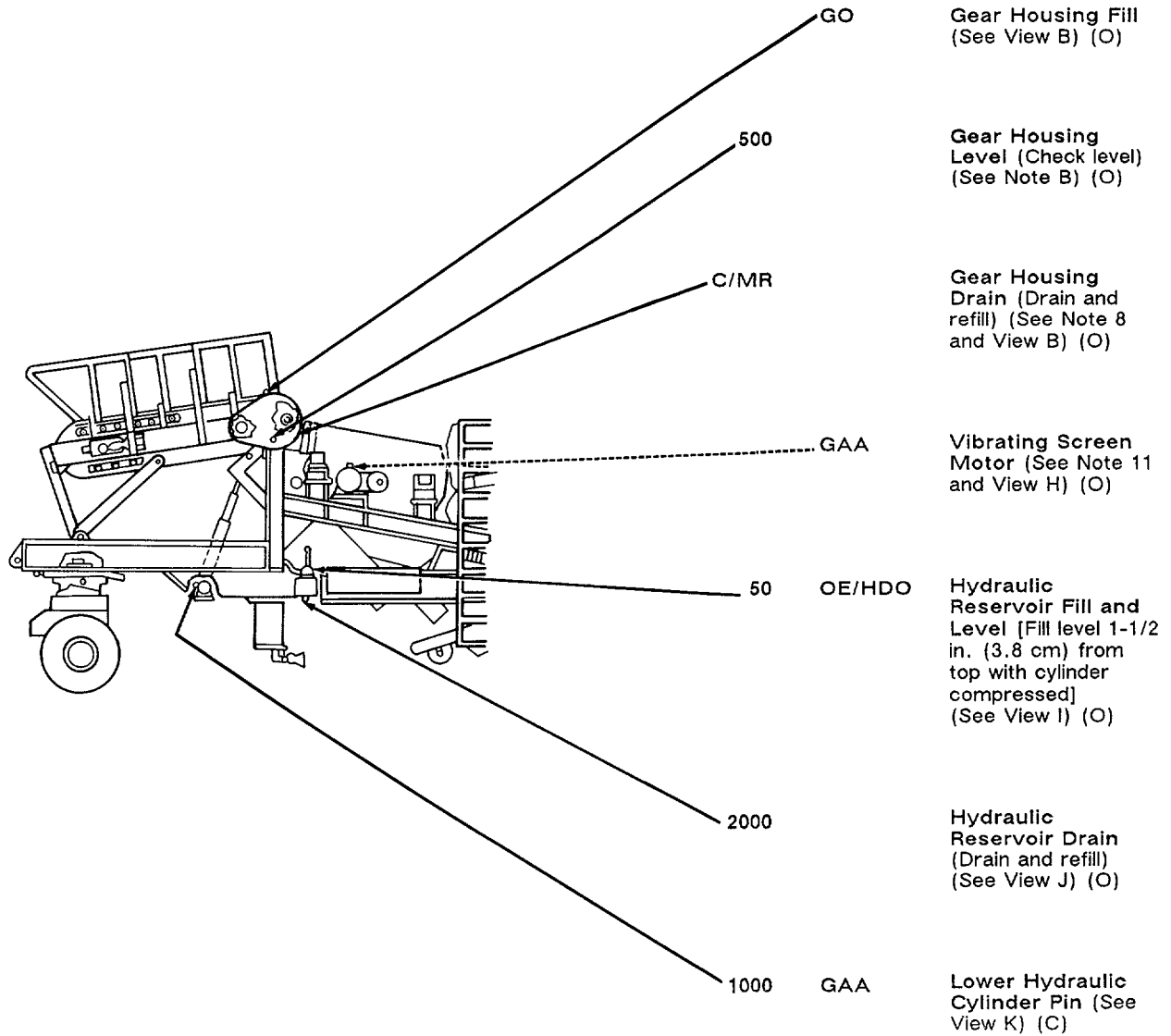

FRONT SECTION, LEFT SIDE (CON'T)

TOTAL MAN-HOURS*		TOTAL MAN-HOURS*	
INTERVAL	MAN-HOUR	INTERVAL	MAN-HOUR
15	1.0	1000	3.5
500	1.5	2000	0.5

* The time specified is the time required to perform all services at the particular interval (on-condition or hard time).

TA507860

LUBRICANT · INTERVAL

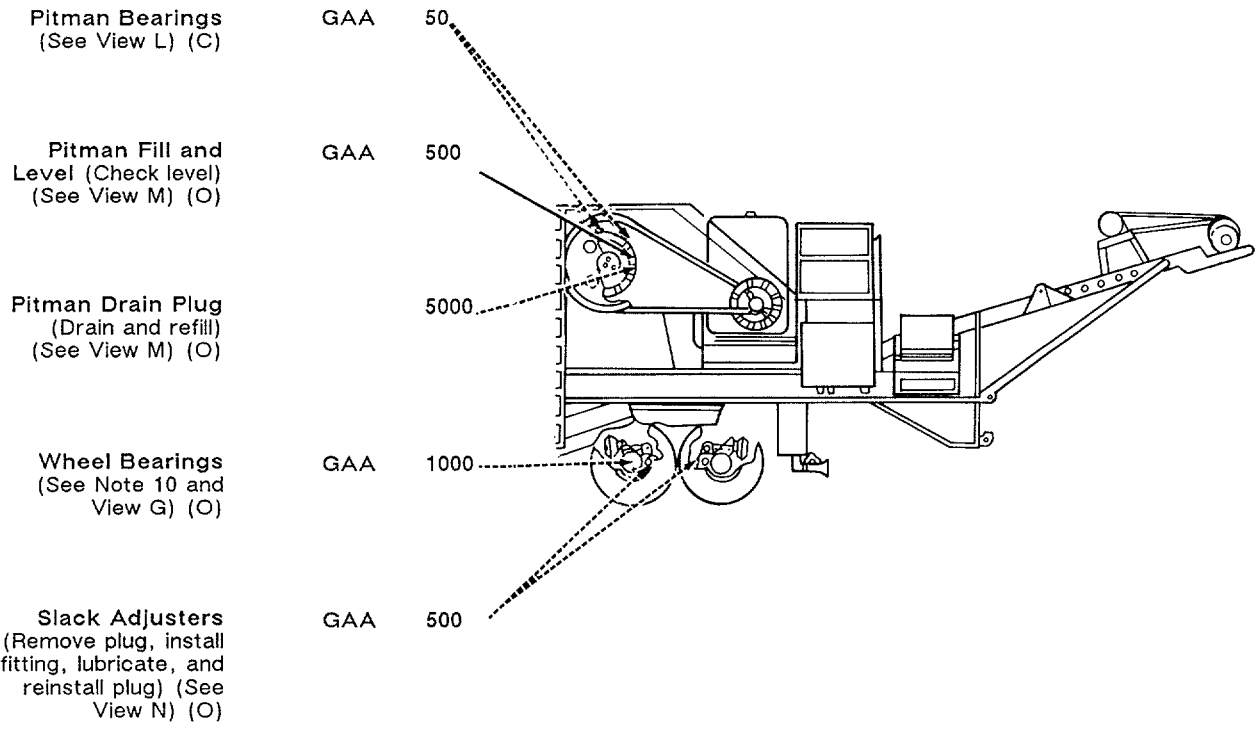

REAR SECTION, LEFT SIDE

TOTAL MAN-HOURS*		TOTAL MAN-HOURS*	
INTERVAL	MAN-HOUR	INTERVAL	MAN-HOUR
50	0.9	1000	3.5
500	1.5	5000	0.8

* The time specified is the time required to perform all services at the particular interval (on-condition or hard time).

TA507861

INTERVAL - LUBRICANT

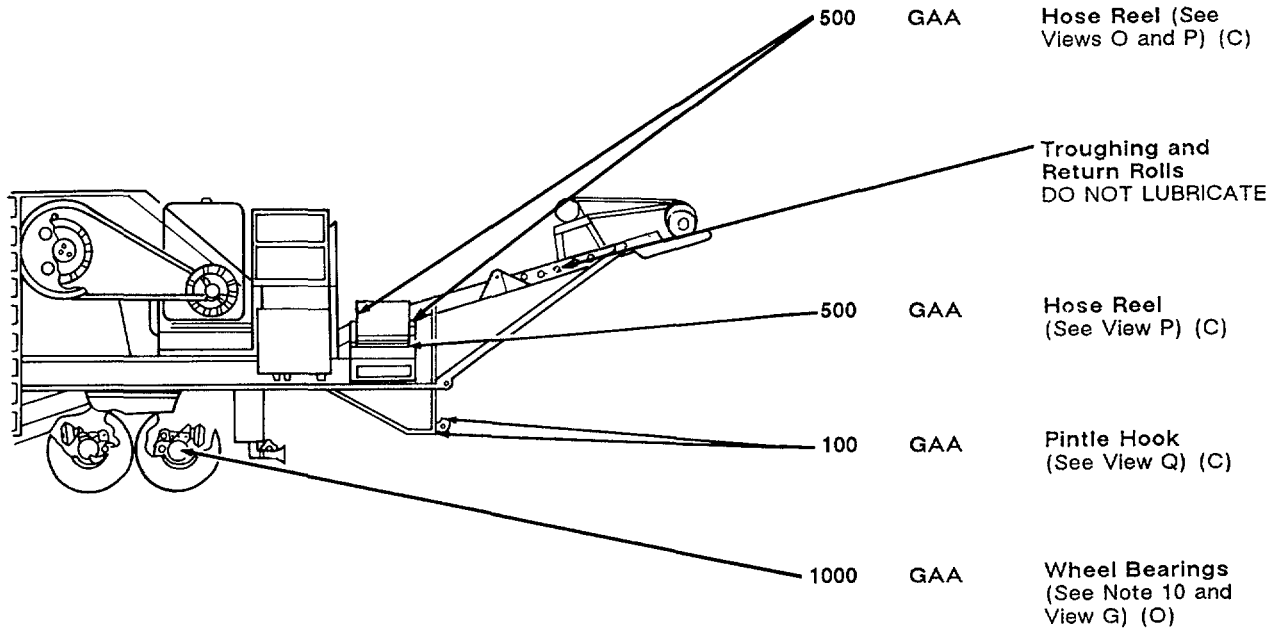

REAR SECTION, LEFT SIDE (CON'T)

TOTAL MAN-HOURS*		TOTAL MAN-HOURS*	
INTERVAL	MAN-HOUR	INTERVAL	MAN-HOUR
10	1.0	1000	3.5
500	1.5		

* The time specified is the time required to perform all services at the particular interval (on-condition or hard time).

TA507862

LUBRICANT · INTERVAL

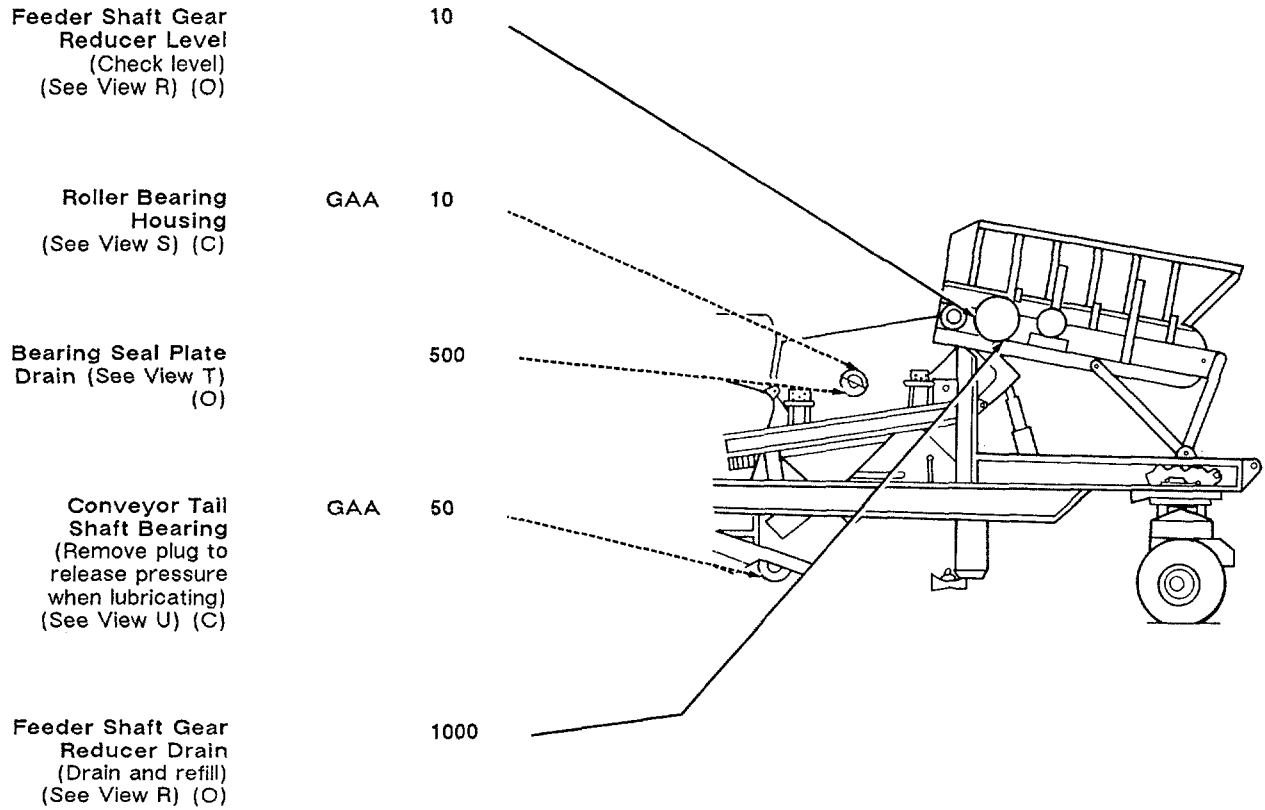

FRONT SECTION, RIGHT SIDE

TOTAL MAN-HOURS*		TOTAL MAN-HOURS*	
INTERVAL	MAN-HOUR	INTERVAL	MAN-HOUR
10	1.0	500	1.5
50	0.9	1000	3.5

* The time specified is the time required to perform all services at the particular interval (on-condition or hard time).

TA507863

INTERVAL • LUBRICANT

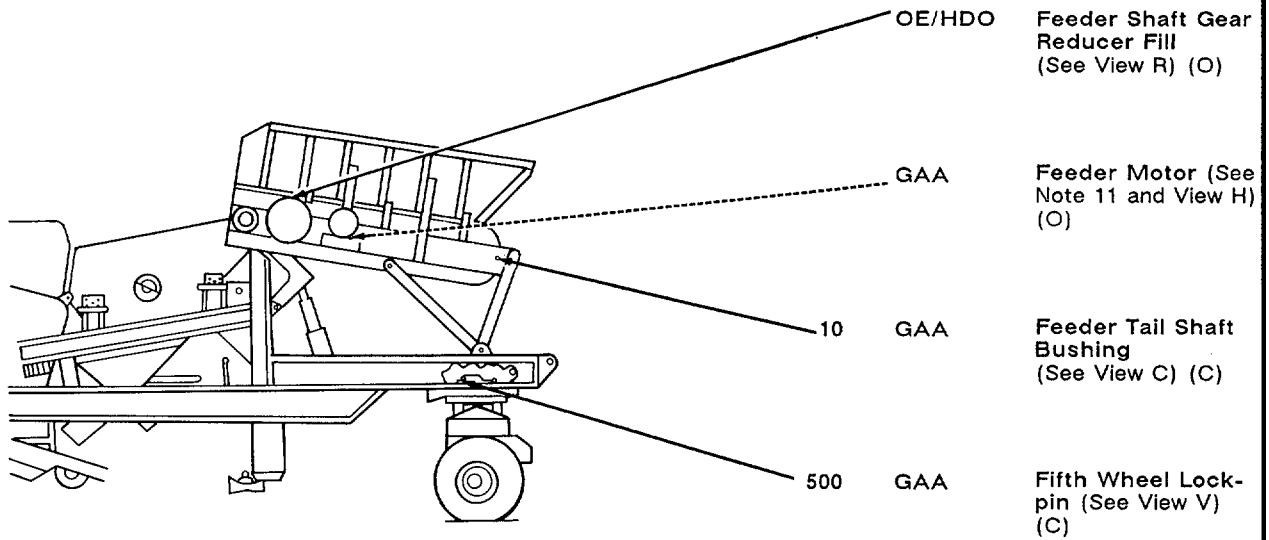

FRONT SECTION, RIGHT SIDE (CON'T)

TOTAL MAN-HOURS*		TOTAL MAN-HOURS*	
INTERVAL	MAN-HOUR	INTERVAL	MAN-HOUR
10	1.0	500	1.5

* The time specified is the time required to perform all services at the particular interval (on-condition or hard time).

TA507864

LUBRICANT • INTERVAL

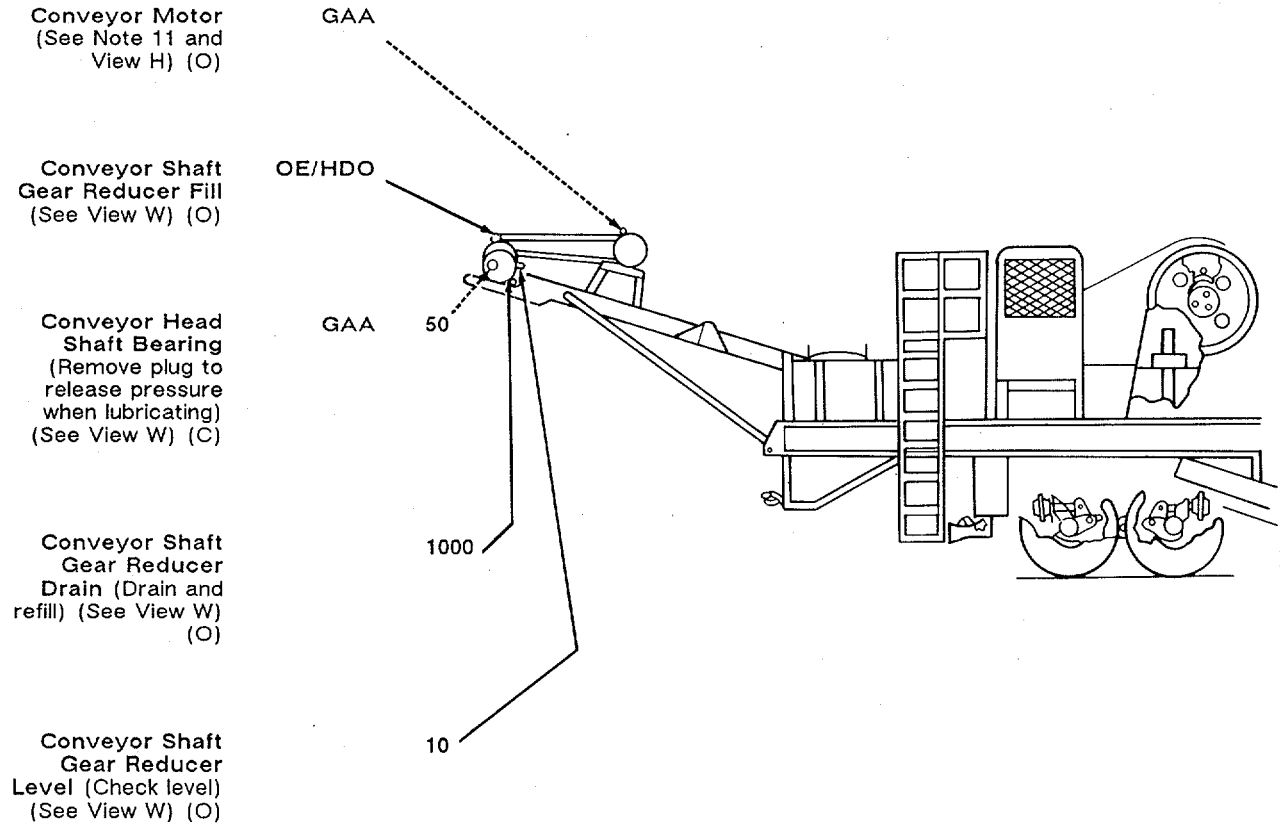

REAR SECTION, RIGHT SIDE

TOTAL MAN-HOURS*		TOTAL MAN-HOURS*	
INTERVAL	MAN-HOUR	INTERVAL	MAN-HOUR
10	1.0	1000	3.5
50	0.9		

* The time specified is the time required to perform all services at the particular interval (on-condition or hard time).

TA507865

INTERVAL • LUBRICANT

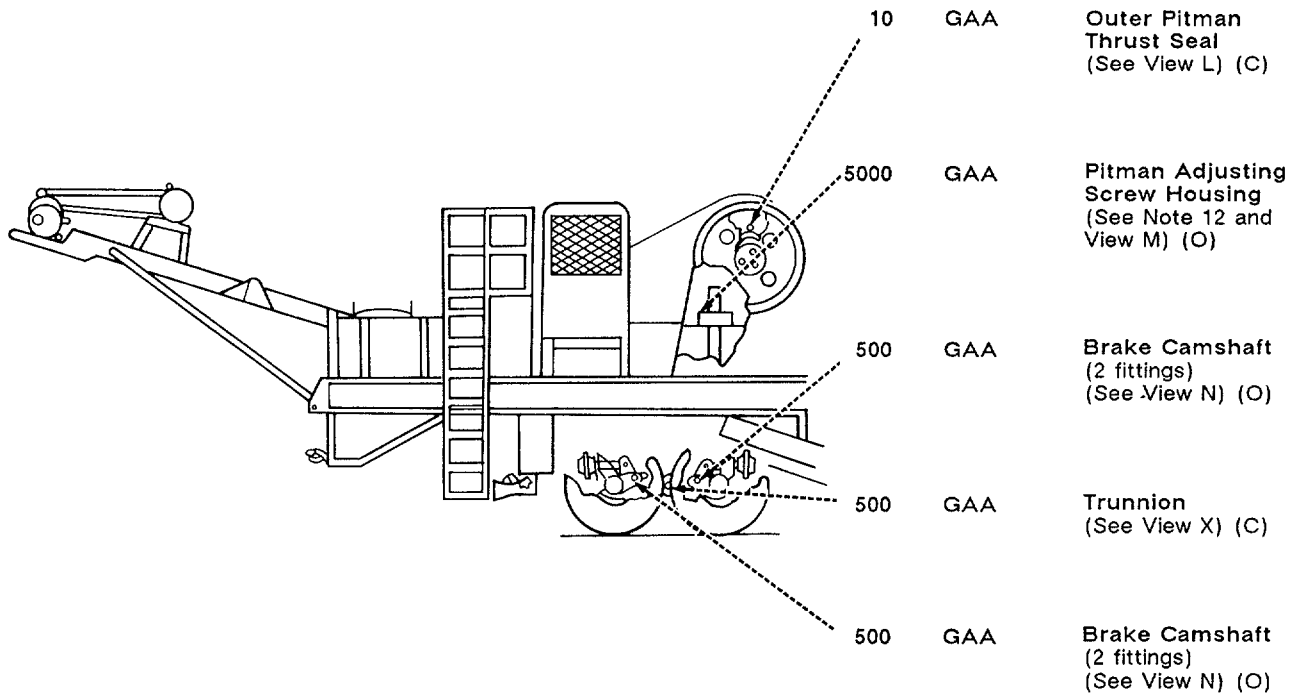

REAR SECTION, RIGHT SIDE (CON'T)

TOTAL MAN-HOURS*		TOTAL MAN-HOURS*	
INTERVAL	MAN-HOUR	INTERVAL	MAN-HOUR
10	1.0	5000	0.8
500	1.5		

* The time specified is the time required to perform all services at the particular interval (on-condition or hard time).

LUBRICANT - INTERVAL

INTERVAL - LUBRICANT

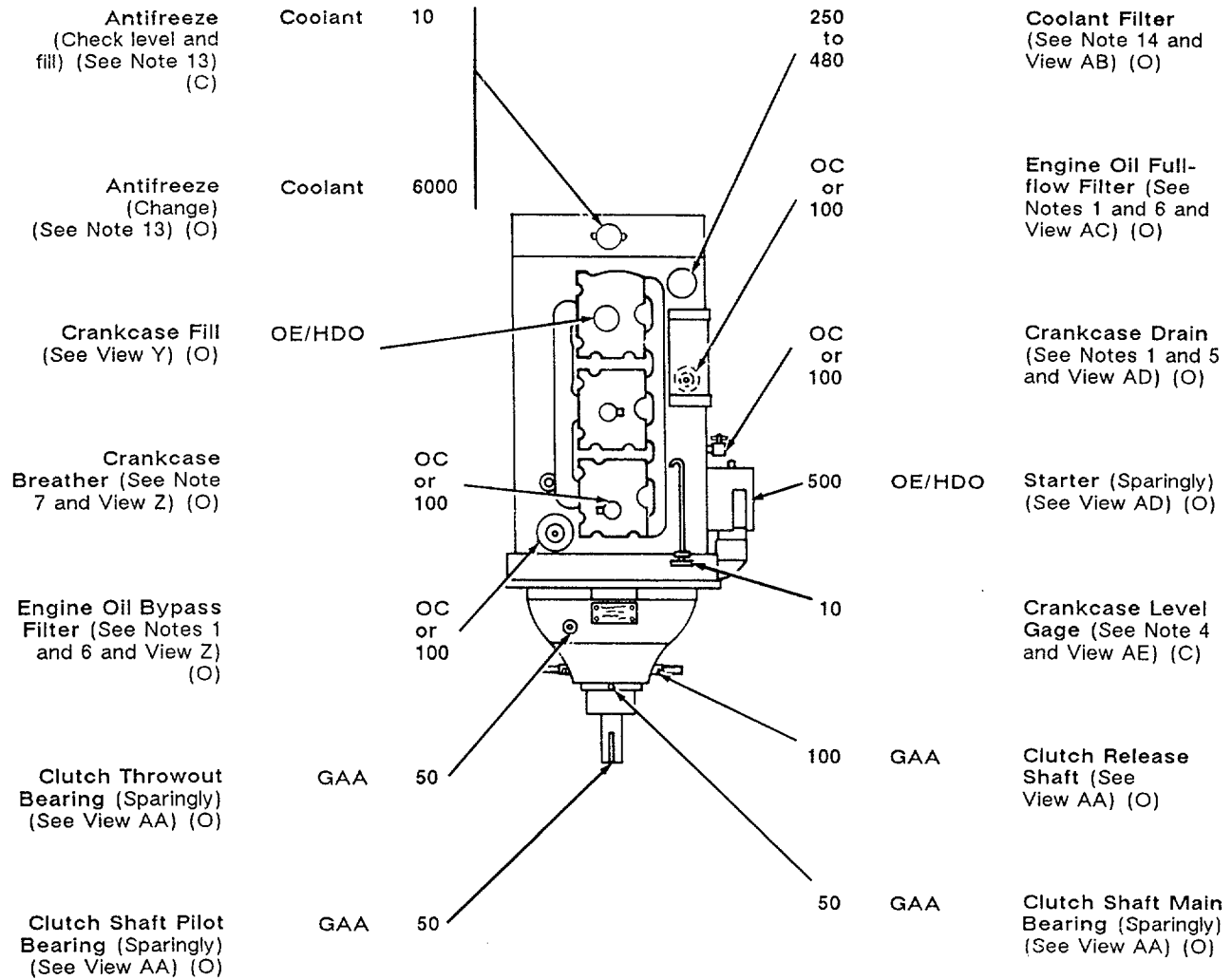

ENGINE

TOTAL MAN-HOURS*		TOTAL MAN-HOURS*	
INTERVAL	MAN-HOUR	INTERVAL	MAN-HOUR
10	1.0	250-480	1.0
50	0.9	500	1.5
100	1.0	6000	2.0

* The time specified is the time required to perform all services at the particular interval (on-condition or hard time).

TA507867

— KEY —

LUBRICANTS	CAPACITIES	EXPECTED TEMPERATURES			INTERVALS
		ABOVE +32°F (ABOVE +0°C)	+40°F to -10°F (+4°C to -23°C)	0°F to -65°F (-18°C to -54°C)	
OE/HDO (MIL-L-2104) Lubricating Oil, ICE, Tactical		OE/HDO 30	OE/HDO 10	—	C/MR: Condi- tion Monitor OC: On-con- dition, as directed by AOAP labora- tory Intervals given are in hours of normal opera- tion.
OEA (MIL-L-46167) Lubricating Oil, ICE, Arctic		—	—	OEA	
Engine Crankcase	28 qt (26.5 l)				
Engine Oil Full- flow Filter	2 qt (1.9 l)				
Engine Oil Bypass Filter	0.7 qt (0.66 l)				
Conveyor Shaft Gear Reducer	3-3/4 qt (3.5 l)				
Feeder Shaft Gear Reducer	8 qt (7.6 l)				
Hydraulic Reservoir	40 qt (38.8 l)				
Oil Can Points (See Note 3)					
GO (MIL-L-2105) Lubricating Oil, Gear, Multipurpose		80/140	80/90	75	
Gear Housing	4 qt (3.8 l)				
GAA (MIL-G-10924) Grease, Automotive and Artillery		ALL TEMPERATURES			
Pitman	80 lb (36.2 kg)				
(MIL-A-46153) Antifreeze, Ethylene Glycol Inhibited		REGULAR	REGULAR	—	
(MIL-A-11755) Antifreeze, Arctic Type		—	—	ARCTIC	

FOR ARCTIC OPERATION REFER TO FM 9-207

TA507868

(A) Head Shaft Bearing

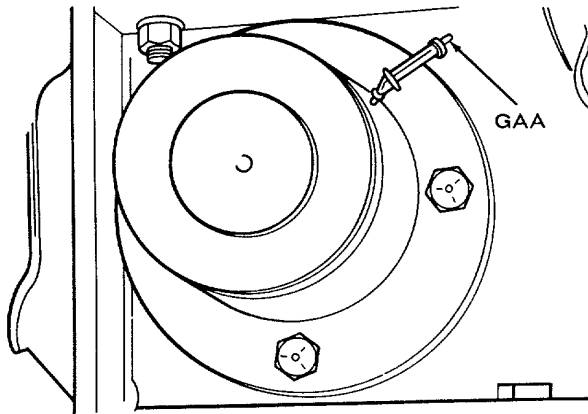

(B) Countershaft Bearing and Gear Housing Fill, Level, and Drain

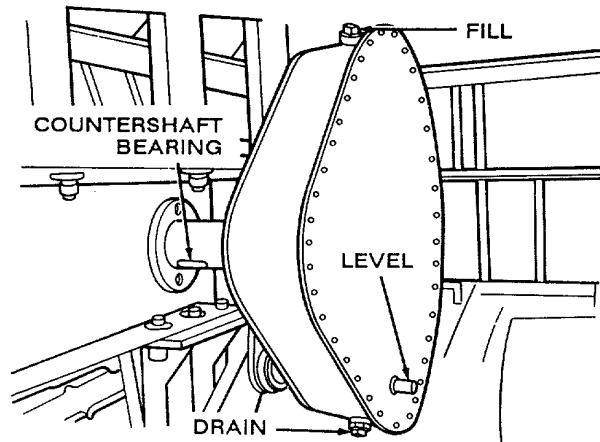

(C) Feeder Chains and Tail Shaft Bushing

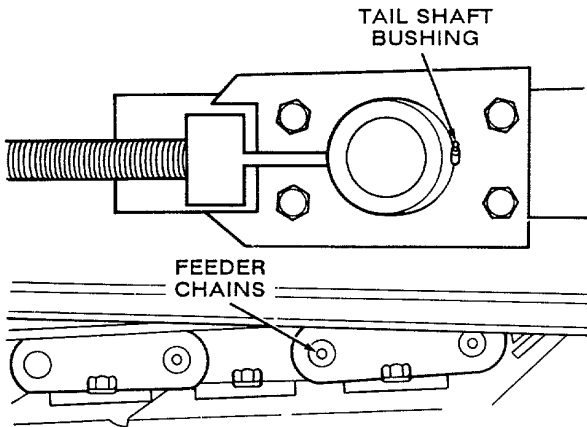

(D) Upper Hydraulic Cylinder Pin

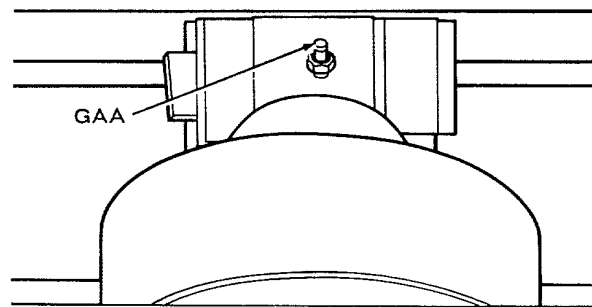

(E) Fifth Wheel Plate and Hinge Pins

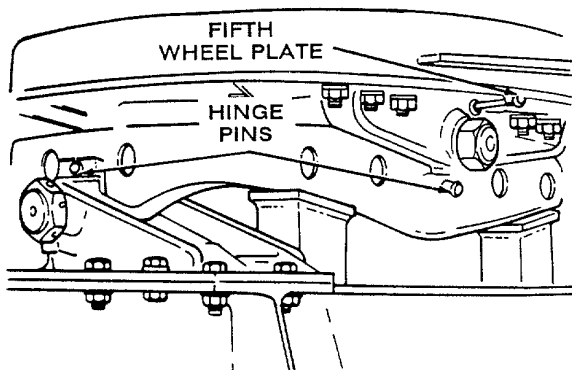

(F) Fifth Wheel Hinge Pin

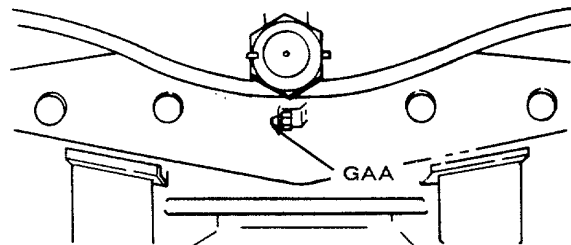

TA507869

G Wheel Bearings

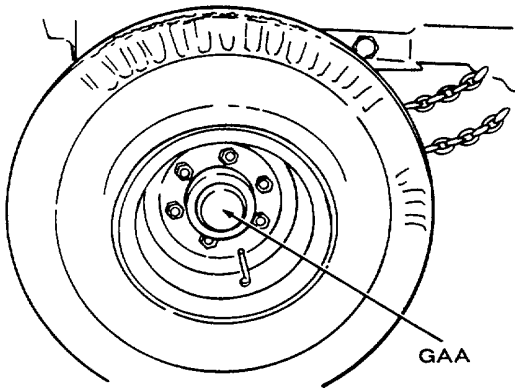

H Vibrating Screen, Feeder, and Conveyor Motors

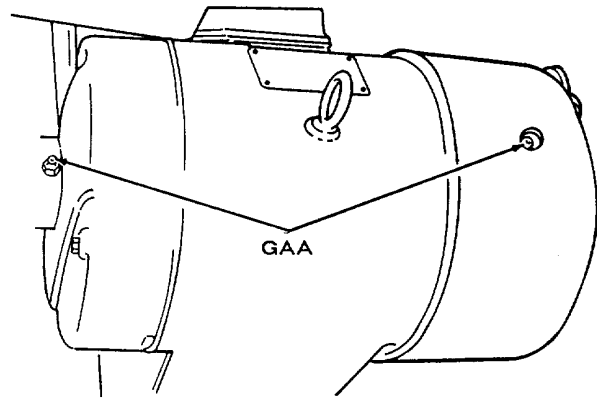

I Hydraulic Reservoir Fill and Level

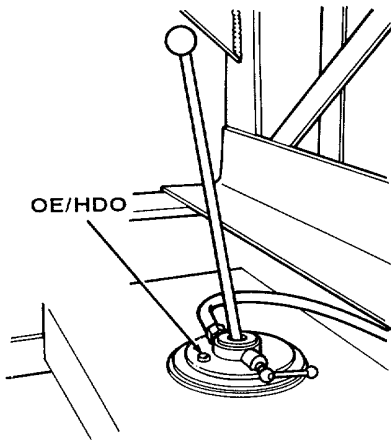

J Hydraulic Reservoir Drain

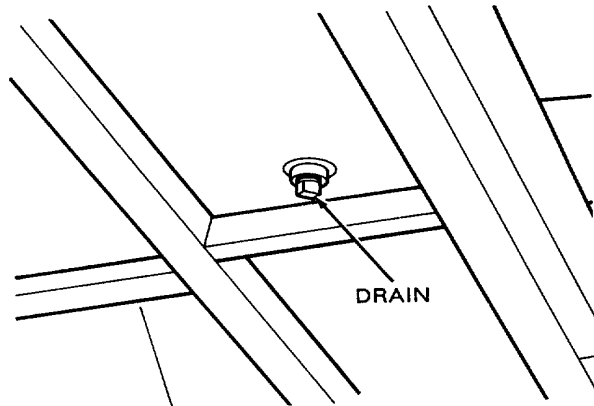

K Lower Hydraulic Cylinder Pin

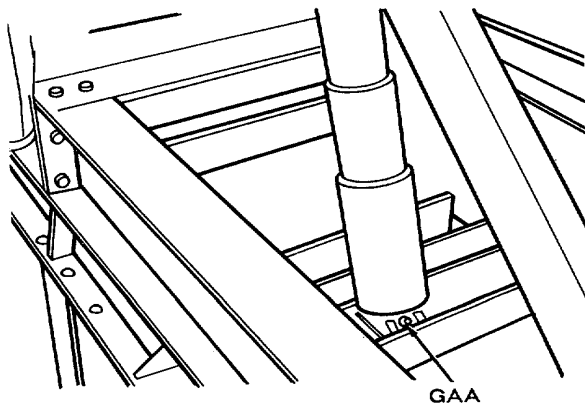

L Pitman Bearings and Outer Pitman Thrust Seal

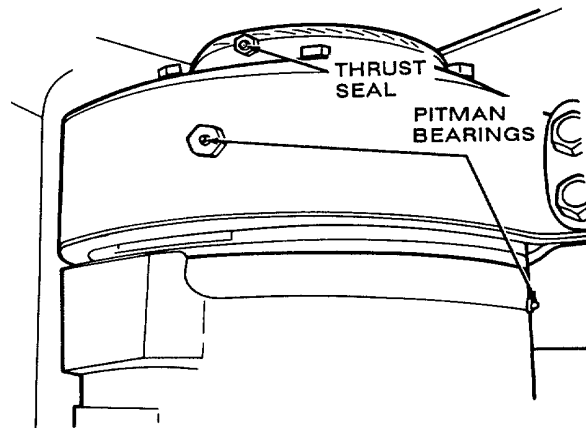

TA507870

M Pitman Fill, Level, and Drain, and Pitman Adjusting Screw Housing

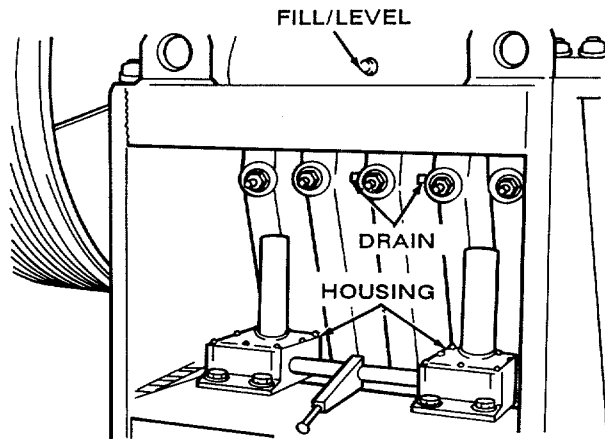

N Brake Camshaft and Slack Adjuster

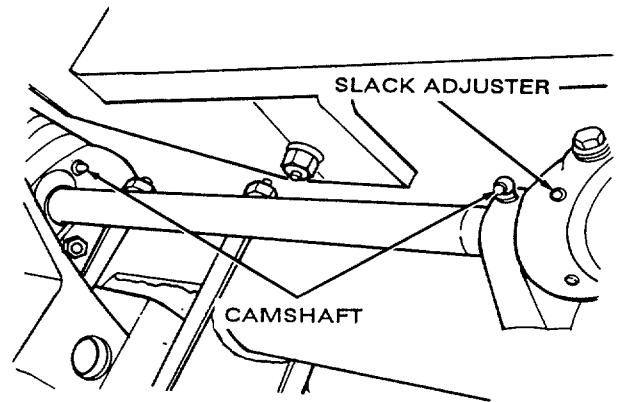

O Hose Reel

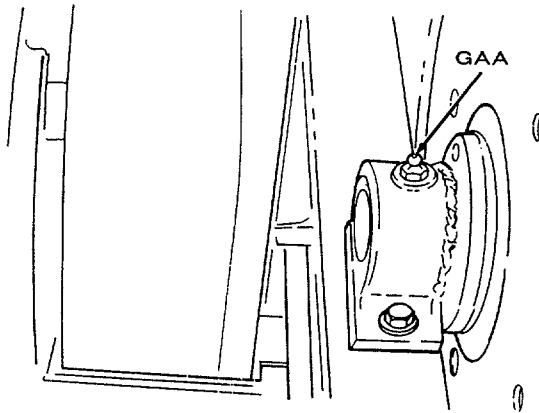

P Hose Reel

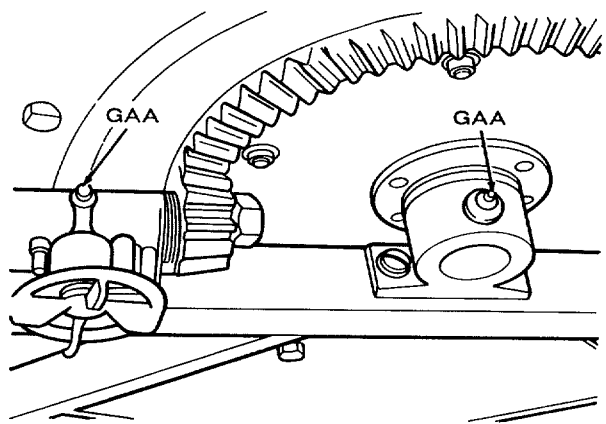

Q Pintle Hook

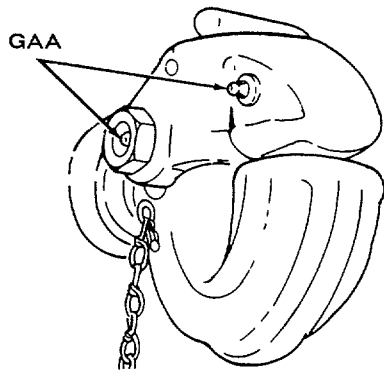

R Feeder Shaft Gear Reducer Fill, Level, and Drain

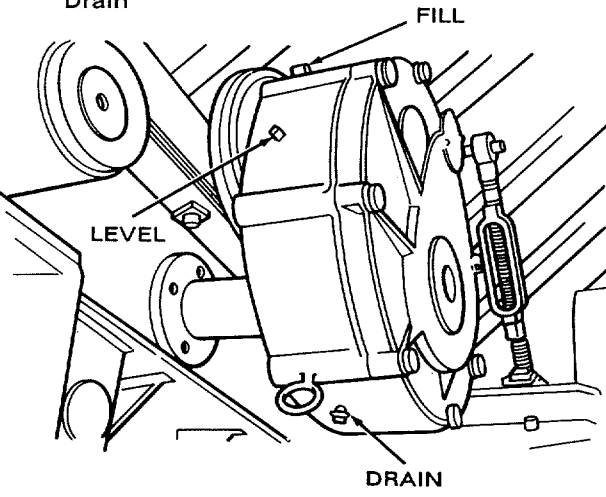

TA507871

S Roller Bearing Housing

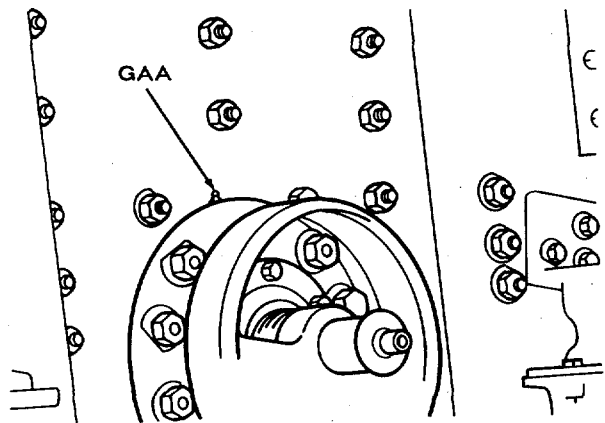

T Bearing Seal Plate Drain

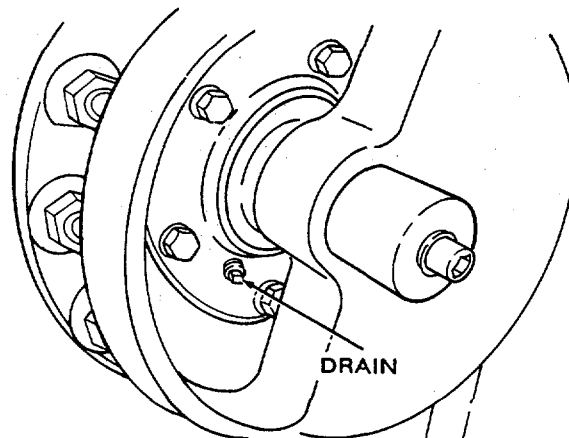

U Conveyor Tail Shaft Bearing

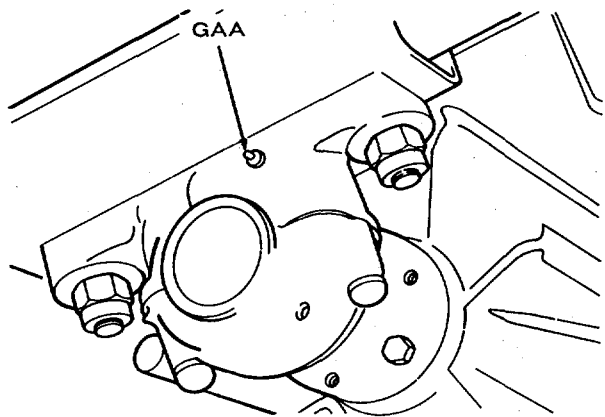

V Fifth Wheel Lockpin

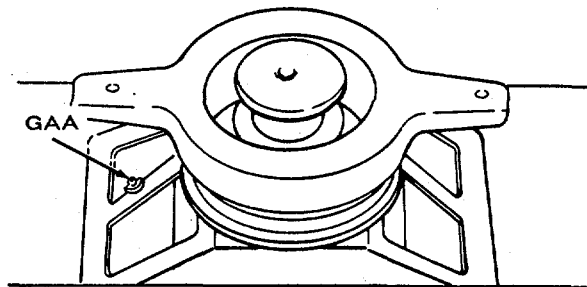

W Conveyor Shaft Gear Reducer Fill, Level, and Drain, and Conveyor Head Shaft Bearing

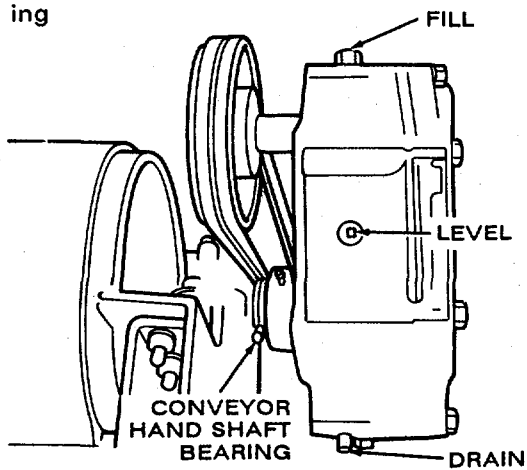

X Trunnion

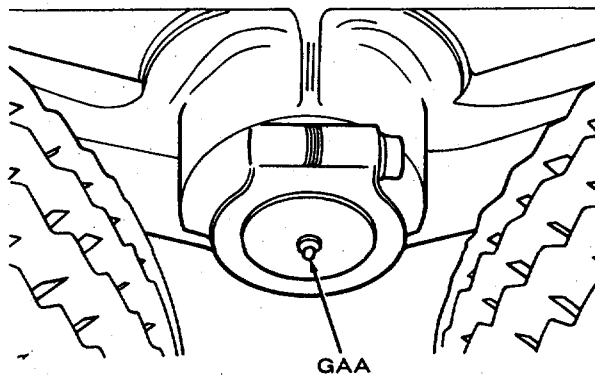

TA507872

Y Crankcase Fill

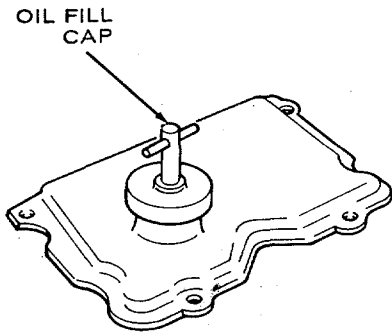

Z Crankcase Breather and Engine Oil Bypass Filter

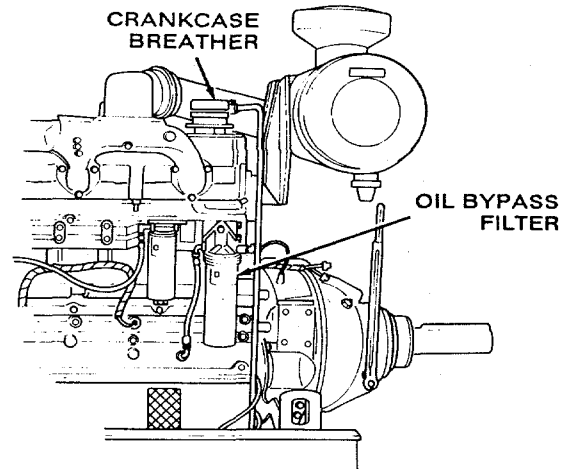

AA Clutch Lubrication Points

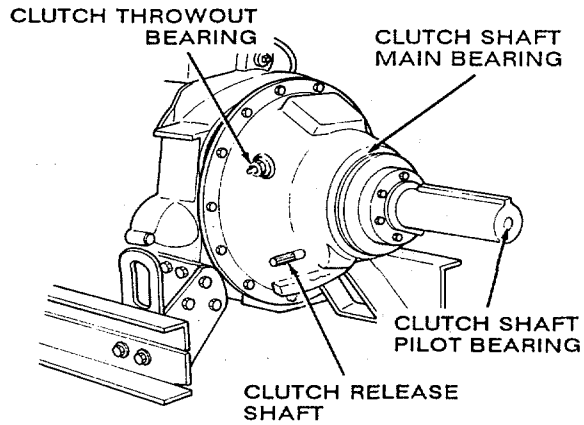

AB Coolant Filter

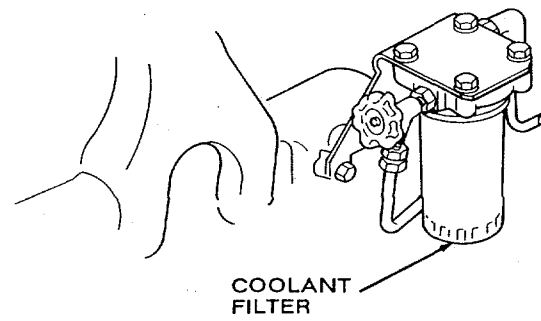

AC Engine Oil Full-flow Filter

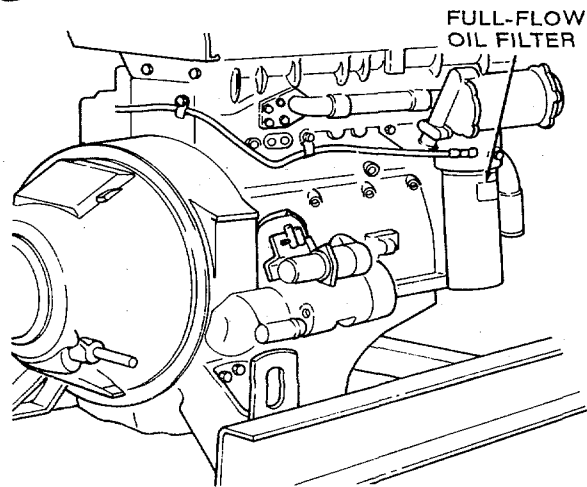

AD Crankcase Drain and Starter

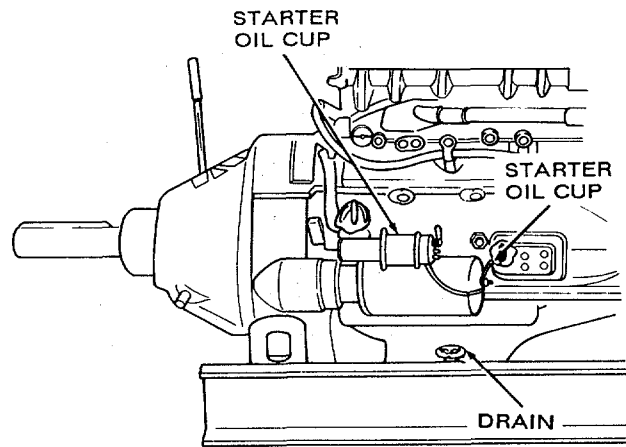

TA507873

AE Crankcase Level Gage

**CRANKCASE
LEVEL GAGE**

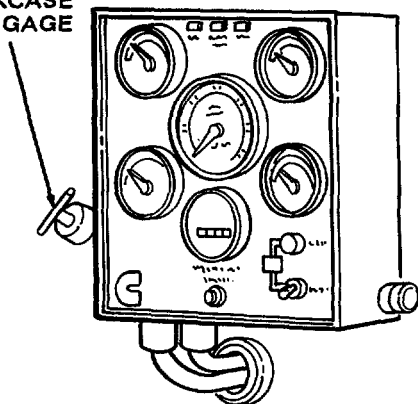

NOTES:

1. **ARMY OIL ANALYSIS PROGRAM (AOAP).** For Active Army units, obtain samples from engine every 50 hours of operation or 60 days, whichever comes first. Reserve and National Guard activities will use 50 hours or 120 days as the prescribed sample intervals. Reserve and National Guard equipment in frequent use during active training period will adhere to the schedule for Active Army units. As a minimum, one sample from each unit's two week active training period will be submitted for each item of equipment. Send oil samples as soon as they have been taken to the nearest AOAP laboratory. Refer to TB 43-0210 for sampling instructions. When or if AOAP laboratory support is unavailable, hard time intervals will apply.

2. **FOR OPERATION OF EQUIPMENT IN PROTRACTED COLD TEMPERATURES BELOW -15°F (-26° C).** Remove lubricants prescribed in Key for temperatures above -15°F (-26° C). Relubricate with lubricants specified in Key for temperatures below -15°F (-260C).

3. **OIL CAN POINTS.** Every 50 hours lubricate linkage pins, throttle and governor linkage, clevises, all exposed adjusting threads, and leveling jacks with OE/HDO as needed.

4. **CRANKCASE OIL LEVEL HOT OR COLD CHECK.** Oil level should be at H (High) mark on dipstick if engine is cold. If engine has been running, shut down engine and allow to sit five minutes before checking; oil level should be between H (High) and L (Low) marks on dipstick.

NOTE

OEIHDO 15140 may be used instead of OE/HDO 30 at +5° F (-15° C) and above.

5. **CRANKCASE.** Oil is to be changed each time an engine oil change is directed by AOAP laboratory. When AOAP laboratory support is not available, change oil every 100 hours. Drain when lubricant is warm.

6. **ENGINE OIL FILTER.** Replace filter element each time an engine oil change is directed by AOAP laboratory. Fill new oil filters with clean oil and install. Fill crankcase, operate engine five minutes, and check for leaks. Shut down engine, wait five minutes, check crankcase level and bring to H (High) mark. When AOAP laboratory support is not available, install new filters every 100 hours.

7. **CRANKCASE BREATHER.** Disassemble crankcase breather and clean or replace element and gasket when oil and filter are changed, or every 100 hours if hard time is used as a guideline.

8. **GEAR HOUSING.** Every 500 hours check level. Change gear lubricant only when required by maintenance repair action, contamination by water, or other foreign material. After refill, operate for five minutes, check for leaks, and bring oil level to level plug opening.

9. **FEEDER CHAINS.** Lubricate three chains, 40 fittings each chain; rotate to locate fittings.

TA507874

NOTES (CON'T):

10. **WHEEL BEARINGS.** Every 1000 hours remove wheels, clean and inspect all parts, replace damaged or worn parts, repack wheel bearings, and assemble.
11. **ALL MOTOR BEARINGS.** To be lubricated only at time of disassembly. After lubrication, remove fittings and install plugs.
12. **PITMAN ADJUSTING SCREW HOUSING.** Every 5000 hours remove cover, clean and inspect all parts, repack housing, and install cover.
13. **ANTIFREEZE.**

WARNING

Cooling system is pressurized. Remove radiator cap slowly and only when engine has cooled below +120° F (+49° C) or painful burns could result.

CAUTION

Do not add cold coolant to a hot engine or engine may be damaged. Allow engine to cool below +120°F (+49° C) before adding coolant.

Check coolant level in radiator. Coolant should be 1 in. (2.5 cm) from bottom of filler neck. If coolant is low, add a 50/50 mixture of antifreeze and water to radiator until proper level is reached.

Change coolant every two years, or 6000 hours, whichever comes first. When changing coolant, DCA4 corrosion inhibitor must be added to cooling system by installing precharge filter WF2053. Test coolant for proper amount of inhibitor: There should be between one and two units of DCA4 corrosion inhibitor per gallon of coolant (water and antifreeze). Refer to TM 5-3820-205-20-2.

14. **COOLANT FILTER.** Change coolant filter each time the engine lubricating oil is changed, or every 250 to 480 hours if hard time is used. The coolant filter contains four units of DCA4 corrosion inhibitor for replenishment of coolant inhibitor level. Test coolant for proper amount of DCA4 corrosion inhibitor each time the coolant filter is changed. Refer to **TM 5-3820-205-20-2.**

A copy of this Lubrication Order will remain with the equipment at all times. Instructions contained herein are mandatory.

By Order of the Secretary of the Army:

GORDON R. SULLIVAN
General, United States Army
Chief of Staff

Official:

PATRICIA P. HICKERSON
Brigadier General, United States Army
The Adjutant General

Distribution:

To be distributed in accordance with DA Form 12-25-E, Block 4133 Operator and Unit maintenance requirement for LO 5-3820-205-12-2.

PIN: 055974-000
TA507875

RECOMMENDED CHANGES TO EQUIPMENT TECHNICAL PUBLICATIONS



SOMETHING WRONG WITH PUBLICATION

FROM: (PRINT YOUR UNIT'S COMPLETE ADDRESS)

DATE SENT

PUBLICATION NUMBER

PUBLICATION DATE

PUBLICATION TITLE

BE EXACT PIN-POINT WHERE IT IS

PAGE NO.

PARA-GRAPH

FIGURE NO.

TABLE NO.

IN THIS SPACE, TELL WHAT IS WRONG AND WHAT SHOULD BE DONE ABOUT IT.

TEAR ALONG PERFORATED LINE

PRINTED NAME, GRADE OR TITLE AND TELEPHONE NUMBER

SIGN HERE

THE METRIC SYSTEM AND EQUIVALENTS

WEIGHT MEASURE

1 Centimeter = 10 Millimeters = 0.01 Meters = 0.3937 Inches
 1 Meter = 100 Centimeters = 1000 Millimeters = 39.37 Inches
 1 Kilometer = 1000 Meters = 0.621 Miles

WEIGHTS

1 Gram = 0.001 Kilograms = 1000 Milligrams = 0.035 Ounces
 1 Kilogram = 1000 Grams = 2.2 lb.
 1 Metric Ton = 1000 Kilograms = 1 Megagram = 1.1 Short Tons

LIQUID MEASURE

1 Milliliter = 0.001 Liters = 0.0338 Fluid Ounces
 1 Liter = 1000 Milliliters = 33.82 Fluid Ounces

SQUARE MEASURE

1 Sq. Centimeter = 100 Sq. Millimeters = 0.155 Sq. Inches
 1 Sq. Meter = 10,000 Sq. Centimeters = 10.76 Sq. Feet
 1 Sq. Kilometer = 1,000,000 Sq. Meters = 0.386 Sq. Miles

CUBIC MEASURE

1 Cu. Centimeter = 1000 Cu. Millimeters = 0.06 Cu. Inches
 1 Cu. Meter = 1,000,000 Cu. Centimeters = 35.31 Cu. Feet

TEMPERATURE

$5/9(^{\circ}\text{F} - 32) = ^{\circ}\text{C}$
 212° Fahrenheit is equivalent to 100° Celsius
 90° Fahrenheit is equivalent to 32.2° Celsius
 32° Fahrenheit is equivalent to 0° Celsius
 $9/5^{\circ}\text{C} + 32 = ^{\circ}\text{F}$

APPROXIMATE CONVERSION FACTORS

TO CHANGE	TO	MULTIPLY BY
Inches	Centimeters	2.540
Feet	Meters	0.305
Yards	Meters	0.914
Miles	Kilometers	1.609
Square Inches	Square Centimeters	6.451
Square Feet	Square Meters	0.093
Square Yards	Square Meters	0.836
Square Miles	Square Kilometers	2.590
Acres	Square Hectometers	0.405
Cubic Feet	Cubic Meters	0.028
Cubic Yards	Cubic Meters	0.765
Fluid Ounces	Milliliters	29.573
its	Liters	0.473
arts	Liters	0.946
allons	Liters	3.785
Ounces	Grams	28.349
Pounds	Kilograms	0.454
Short Tons	Metric Tons	0.907
Pound-Feet	Newton-Meters	1.356
Pounds per Square Inch	Kilopascals	6.895
Miles per Gallon	Kilometers per Liter	0.425
Miles per Hour	Kilometers per Hour	1.609

TO CHANGE	TO	MULTIPLY BY
Centimeters	Inches	0.394
Meters	Feet	3.280
Meters	Yards	1.094
Kilometers	Miles	0.621
Square Centimeters	Square Inches	0.155
Square Meters	Square Feet	10.764
Square Meters	Square Yards	1.196
Square Kilometers	Square Miles	0.386
Square Hectometers	Acres	2.471
Cubic Meters	Cubic Feet	35.315
Cubic Meters	Cubic Yards	1.308
Milliliters	Fluid Ounces	0.034
Liters	Pints	2.113
Liters	Quarts	1.057
ers	Gallons	0.264
ms	Ounces	0.035
ograms	Pounds	2.205
Metric Tons	Short Tons	1.102
Newton-Meters	Pounds-Feet	0.738
Kilopascals	Pounds per Square Inch	0.145
ometers per Liter	Miles per Gallon	2.354
ometers per Hour	Miles per Hour	0.621



PIN: 055974-000